

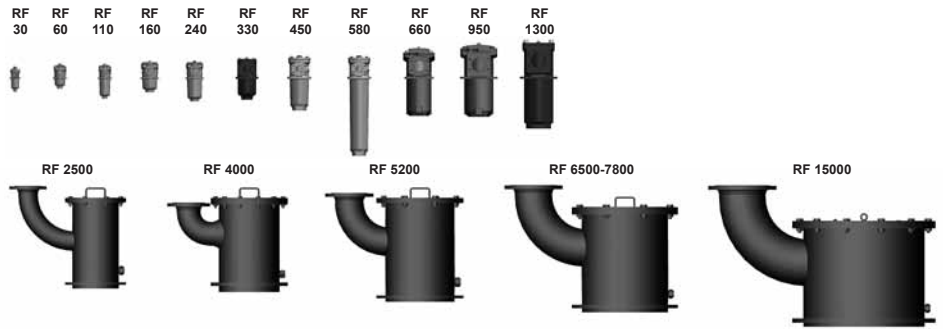

Return Line Filter RF up to 15000 l/min, up to 25 bar



1. TECHNICAL SPECIFICATIONS

1.1 FILTER HOUSING

Construction

The filter housings are designed in accordance with international regulations. They consist of a filter housing and a threaded cover plate. Standard equipment:

- with bypass valve in the element. For RF 450/580 the bypass valve is built into the cover plate as standard.
- connection for a clogging indicator

1.2 FILTER ELEMENTS

HYDAC filter elements are validated and their quality is constantly monitored according to the following standards:

- ISO 2941
- ISO 2942
- ISO 2943
- ISO 3724
- ISO 3968
- ISO 11170
- ISO 16889

Contamination retention capacities in g

		Betamicon® (BN4HC)			
RF	Elements	3 µm	5 µm	10 µm	20 µm
30	1x0030R	2.6	2.9	3.5	4.0
60	1x0060R	5.7	6.3	7.6	8.6
110	1x0110R	12.0	13.3	16.0	18.1
160	1x0160R	18.6	20.7	24.9	28.1
240	1x0240R	29.3	32.5	39.1	44.2
330	1x0330R	38.4	42.6	51.2	57.9
450	1x0450R	49.1	54.4	65.5	74.1
580	1x0580R	124.7	138.2	166.3	188.1
660	1x0660R	87.1	96.5	116.1	131.3
950	1x0950R	130.0	144.1	173.3	196.1
1300	1x1300R	181.0	200.7	241.4	273.1
2500	3x0850R	336.3	372.6	448.5	507.3
4000	5x0850R	560.5	621.0	747.5	845.5
5200	4x1300R	724.0	802.8	965.6	1092.4
6500	5x1300R	905.0	1003.5	1207.0	1365.5
7800	6x1300R	1086.0	1204.2	1448.4	1638.6
15000	10x1300R	1810.0	2007.0	2414.0	2731.0

Filter elements are available with the following pressure stability values:
 Betamicon® (BN4HC): 20 bar
 Paper (P/HC): 10 bar
 Wire mesh (W/HC): 20 bar
 Stainless steel fibre (V): 210 bar
 Betamicon®/Aquamicron® (BN4AM): 10 bar
 Aquamicron® (AM): 10 bar

1.3 FILTER SPECIFICATIONS

Nominal pressure	RF 30, 2500 to 15000: 10 bar	RF 450 and 580: 16 bar	RF 60 to 1300: 25 bar
Temperature range	-10 °C to +100 °C		
Material of filter housing and cover plate	RF 30: PA 66	RF 60 to 580: Aluminium	RF 660 to 1300: EN-GJS-400-15
	RF 2500 to 15000: Welded steel		
Type of clogging indicator	VR Connection thread G ½ (return line indicator up to 25 bar operating pressure)		
	VM Differential pressure indicator only for RF 450 and 580		
Pressure setting of clogging indicator	2 bar (others on request)		
Bypass cracking pressure	3 bar (others on request)		

1.4 SEALS

NBR (= Perbunan)

1.5 INSTALLATION

As tank-top or inline filter. RF 450 and 580 are also suitable for horizontal installation (with check valve).

1.6 SPECIAL MODELS AND ACCESSORIES

On request

1.7 SPARE PARTS

See Original Spare Parts List

1.8 CERTIFICATES AND APPROVALS

On request

1.9 COMPATIBILITY WITH HYDRAULIC FLUIDS ISO 2943

- Hydraulic oils H to HLPD DIN 51524
- Lubrication oils DIN 51517, API, ACEA, DIN 51515, ISO 6743
- Compressor oils DIN 51506
- Biodegradable operating fluids VDMA 24568 HETG, HEES, HEPG
- Fire-resistant fluids HFA, HFB, HFC and HFD
- Operating fluids with high water content (>50% water content) on request

1.10 IMPORTANT INFORMATION

- Filter housings must be earthed.
- When using electrical clogging indicators, the electrical power supply to the system must be switched off before removing the clogging indicator connector.
- Filters must be flexibly mounted and not fixed rigidly to the floor or used as a pipe support.

Symbol for hydraulic systems

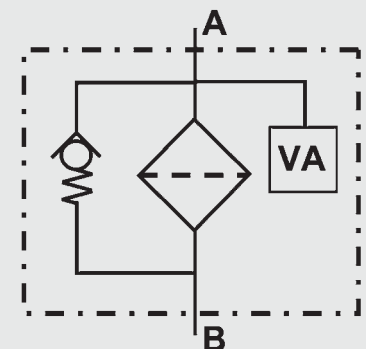

VA = clogging indicator

2. MODEL CODE (also order example)

RF BN/HC 330 D L 10 D 1 . X /-L24

2.1 COMPLETE FILTER

Filter type _____

RF

Filter material of filter element _____

BN/HC Betamicon® (BN4HC) P/HC Paper AM Aquamicon®
 V Stainless steel fibre W/HC Stainl. steel wire mesh BN/AM Betamicon®/Aquamicon®

Size of filter or element _____

RF: 30, 60, 110, 160, 240, 330, 450, 580, 660, 950, 1300, 2500, 4000, 5200, 6500, 7800, 15000

Operating pressure _____

B = 10 bar (RF 30, 2500 to 15000)

C = 16 bar (RF 450, 580)

D = 25 bar (RF 60 to 1300)

Type and size of connection _____

Type	Port	Filter size																	
		30	60	110	160	240	330	450	580	660	950	1300	2500	4000	5200	6500	7800	15000	
B	G 1/2	•																	
C	G 3/4		•	•															
E	G 1 1/4			•	•														
G	G 2						•												
L	SAE DN 50 (2")						•	•	•										
M	SAE DN 80 (3")									•									
N*	G 3									•									
O	SAE DN 90 (3 1/2")										•								
P	SAE DN 100 (4")											•							
R	DIN DN 100												•						
U	DIN DN 125													•					
V	DIN DN 150														•				
W	DIN DN 200															•		•	
x	DIN DN 250																•	•	•
Y	DIN DN 300																		•

* This port G3 applies to filter outlet only (filter outlet = SAE DN 80)

Filtration rating in µm _____

BN/HC, V: 3, 5, 10, 20 P/HC: 10, 20 AM: 40
 W/HC: 25, 50, 100, 200 BN/AM: 3, 10

Type of clogging indicator _____

Y plastic blanking plug in indicator port
 A steel blanking plug in indicator port
 B visual
 C electrical
 D visual and electrical
 for other clogging indicators, see brochure no. 7.050../..

Type code _____

1 standard connection (only RF 30 to 1300)
 2 RF 2500 to 15000: outlet for each filter element location spigot has threaded connection for pipe extension
 3 RF 2500 to 15000: common elbow outlet

Modification number _____

X the latest version is always supplied

Supplementary details _____

B cracking pressure of bypass (e.g. B6 = 6 bar)
 DE differential pressure measurement across element (RF 660, 950, 1300)
 DH cover plate lifting device (only RF 2500 to 15000)
 GA mating weld connection flange in steel
 KB without bypass valve
 L... light with appropriate voltage (24V, 48V, 110V, 220V)
 LED 2 light emitting diodes up to 24 Volt
 O O-ring groove on the DIN inlet flange (only for RF 2500 to 15000)
 T with tank breather filter (only RF 30)
 V FPM seals
 only for clogging indicators type D

2.2 REPLACEMENT ELEMENT

0330 R 010 BN4HC /-V

Size _____

0030, 0060, 0110, 0160, 0240, 0330, 0450, 0580, 0660, 0950, 1300

Type _____

R

Filtration rating in µm _____

BN4HC, V: 003, 005, 010, 020 P/HC: 010, 020 AM: 040
 W/HC: 025, 050, 100, 200 BN4AM: 003, 010

Filter material _____

BN4HC, V, W/HC, P/HC, BN4AM, AM

Supplementary details _____

V (for descriptions, see point 2.1)

2.3 REPLACEMENT CLOGGING INDICATOR

VR 2 D . X /-L24

Type of indicator _____

VR return line indicator up to 25 bar operating pressure (for RF 450/580: on request)
 VM differential pressure indicator (only possible for RF 450/580)

Pressure setting _____

2 standard 2 bar, others on request

Type of clogging indicator (see Point 2.1) _____

Modification number _____

X the latest version is always supplied

Supplementary details _____

L..., LED, V (for descriptions, see point 2.1)

3. FILTER CALCULATION / SIZING

The total pressure drop of a filter at a certain flow rate Q is the sum of the housing Δp and the element Δp and is calculated as follows:

$$\Delta p_{\text{total}} = \Delta p_{\text{housing}} + \Delta p_{\text{element}}$$

$$\Delta p_{\text{housing}} = (\text{see Point 3.1})$$

$$\Delta p_{\text{element}} = Q \cdot \frac{SK^*}{1000} \cdot \frac{\text{viscosity}}{30}$$

(*see point 3.2)

For ease of calculation, our Filter Sizing Program is available on request free of charge.

NEW: Sizing online at www.hydac.com

3.1 Δp -Q HOUSING CURVES BASED ON ISO 3968

The housing curves apply to mineral oil with a density of 0.86 kg/dm³ and a kinematic viscosity of 30 mm²/s. In this case, the differential pressure changes proportionally to the density.

RF 30

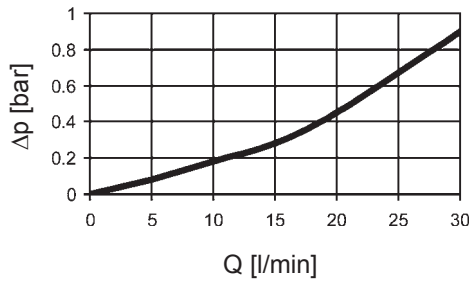

RF 60, 110

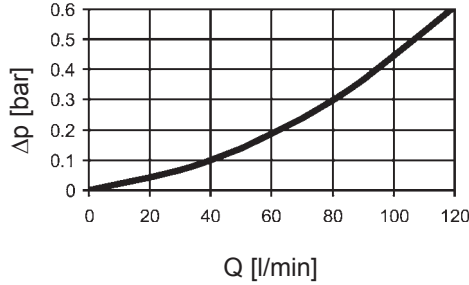

RF 160, 240

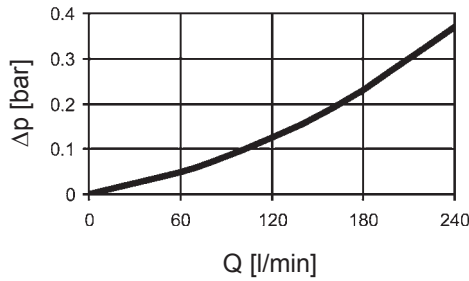

RF 330, 660

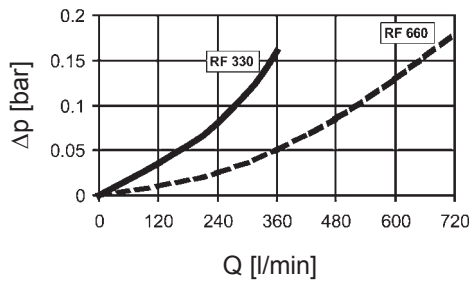

RF 450, 580

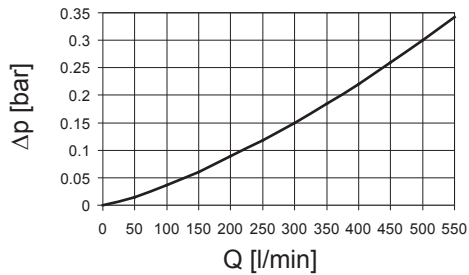

RF 950, 1300

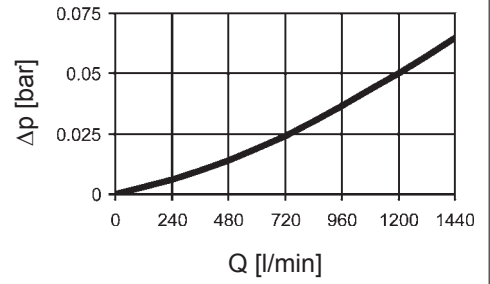

RF 2500, 4000

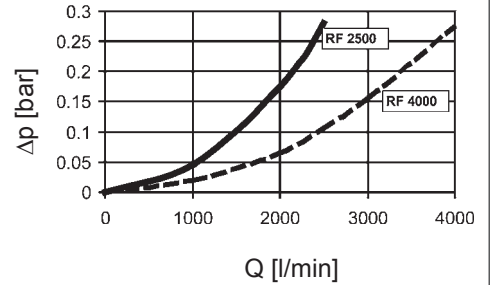

RF 5200, 6500

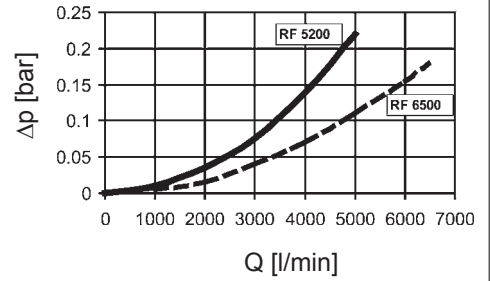

RF 7800, 15000

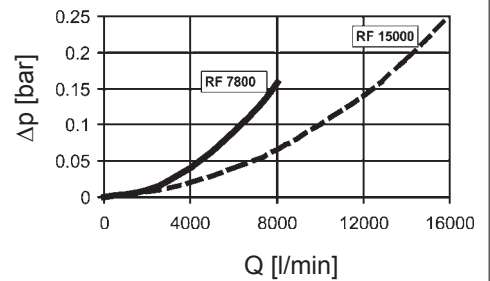

3.2 GRADIENT COEFFICIENTS (SK) FOR FILTER ELEMENTS

The gradient coefficients in mbar/(l/min) apply to mineral oils with a kinematic viscosity of 30 mm²/s. The pressure drop changes proportionally to the change in viscosity.

RF	V				W/HC
	3 μm	5 μm	10 μm	20 μm	
30	19.4	14.2	7.9	3.8	-
60	15.9	9.3	5.4	3.3	0.90
110	7.6	5.1	3.0	2.0	0.495
160	4.9	3.5	2.4	1.5	0.338
240	3.2	2.6	1.7	1.2	0.225
330	2.1	1.7	1.1	0.8	0.162
660	1.0	0.8	0.6	0.4	0.081
950	0.7	0.6	0.4	0.2	0.054
1300	0.5	0.4	0.3	0.2	0.045

For gradient coefficients for RF 450/580, please ask separately!

BN4HC: RF 30

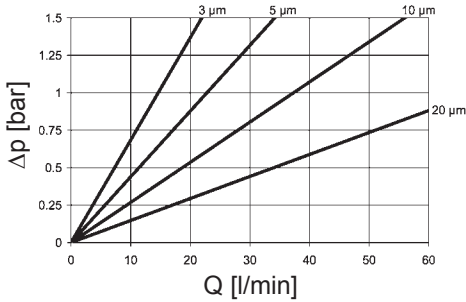

BN4HC: RF 160

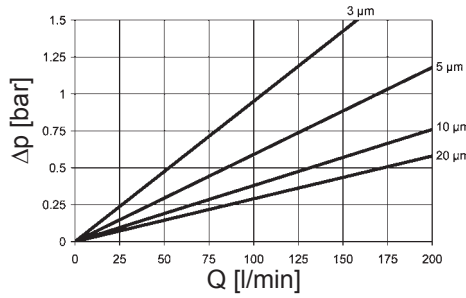

BN4HC: RF 60

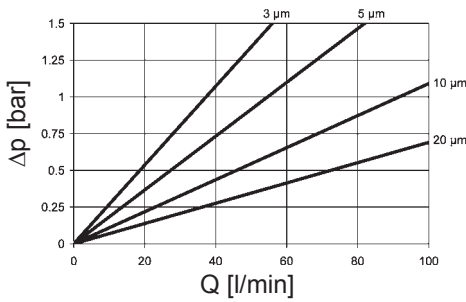

BN4HC: RF 240

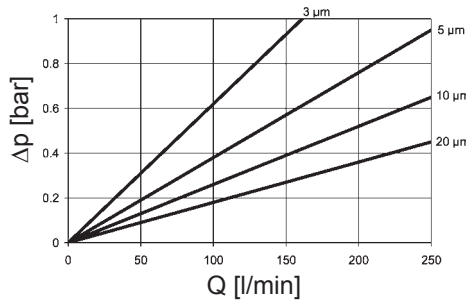

BN4HC: RF 110

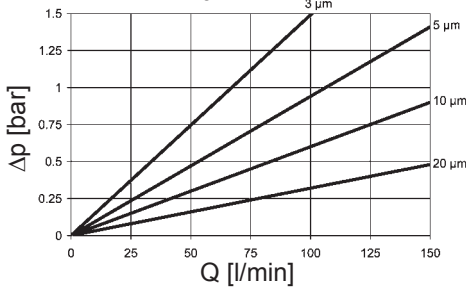

BN4HC: RF 330

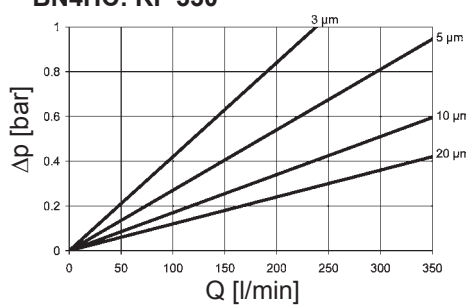

BN4HC: RF 450

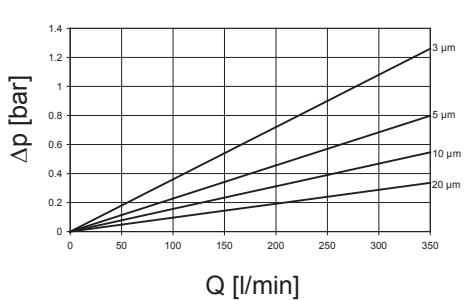

BN4HC: RF 580

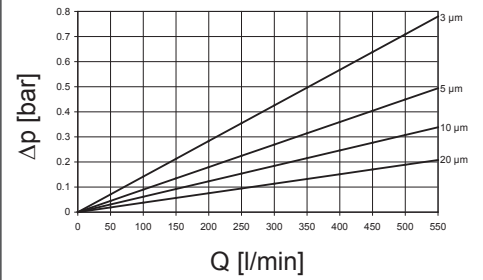

BN4HC: RF 660

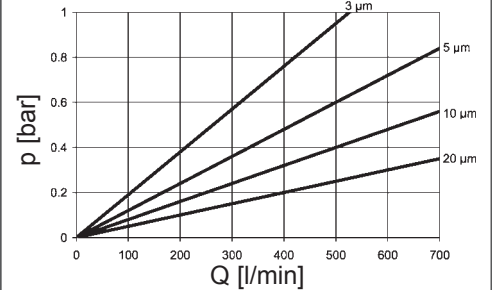

BN4HC: RF 850

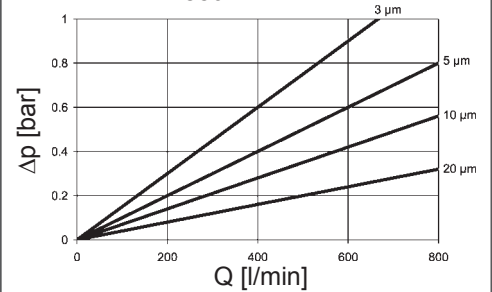

BN4HC: RF 950

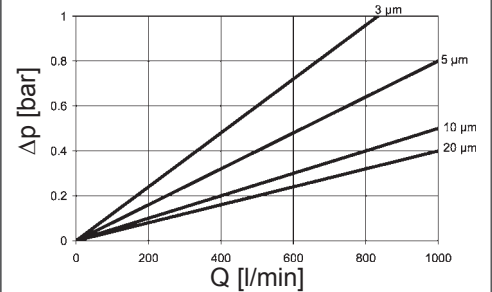

BN4HC: RF 1300

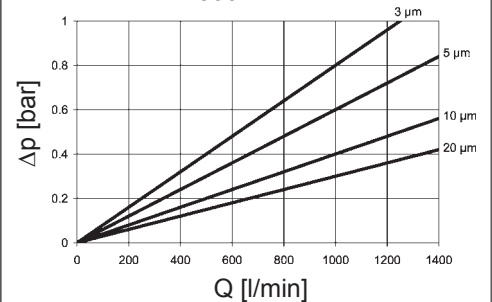

4. DIMENSIONS

RF 30

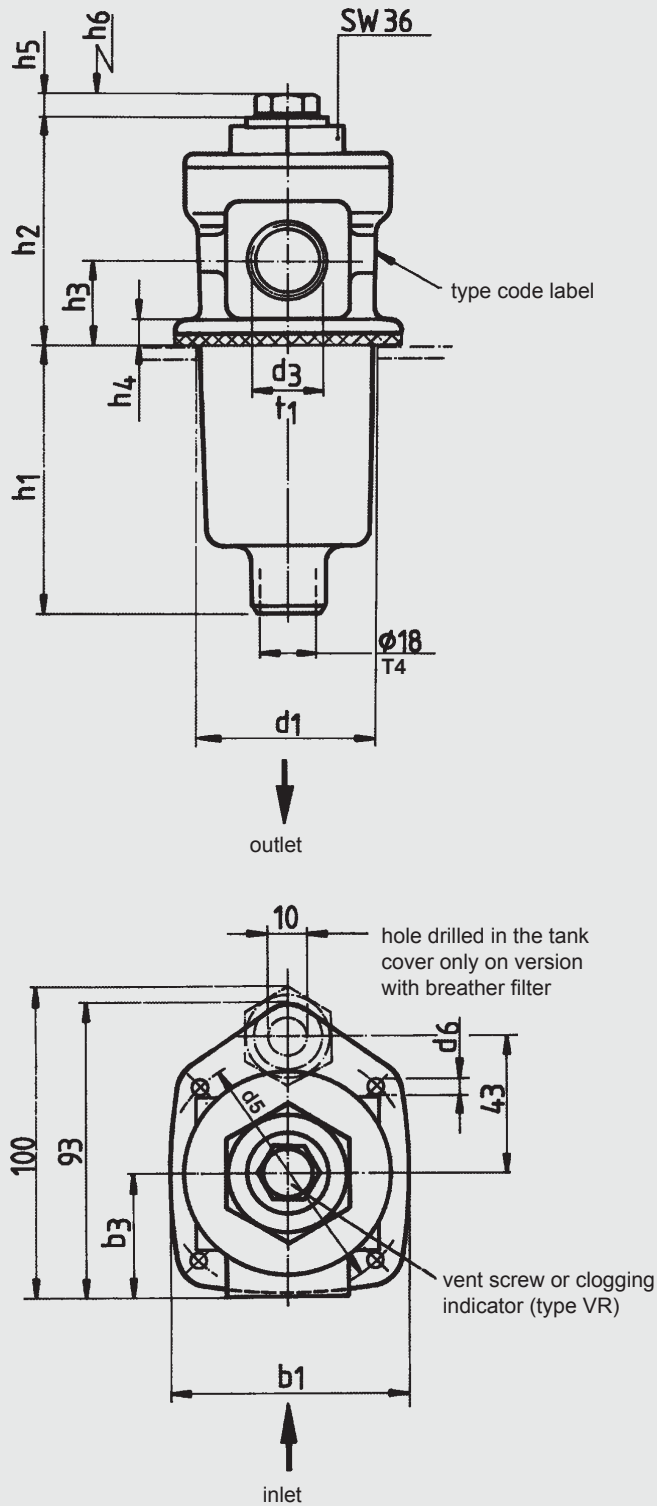

RF	b1	b3	d1	d3 ¹⁾	d5	d6 ²⁾	h1	h2	h3	h4	h5	h6	t1	t4	Weight including element [kg]	Volume of pressure chamber [l]
30	71	38	60	G ½	78	M4	86	70	27	8	11	90	14	14	0.4	0.18

¹⁾ Threaded port to ISO 228 / ²⁾ Mounting hole for screw

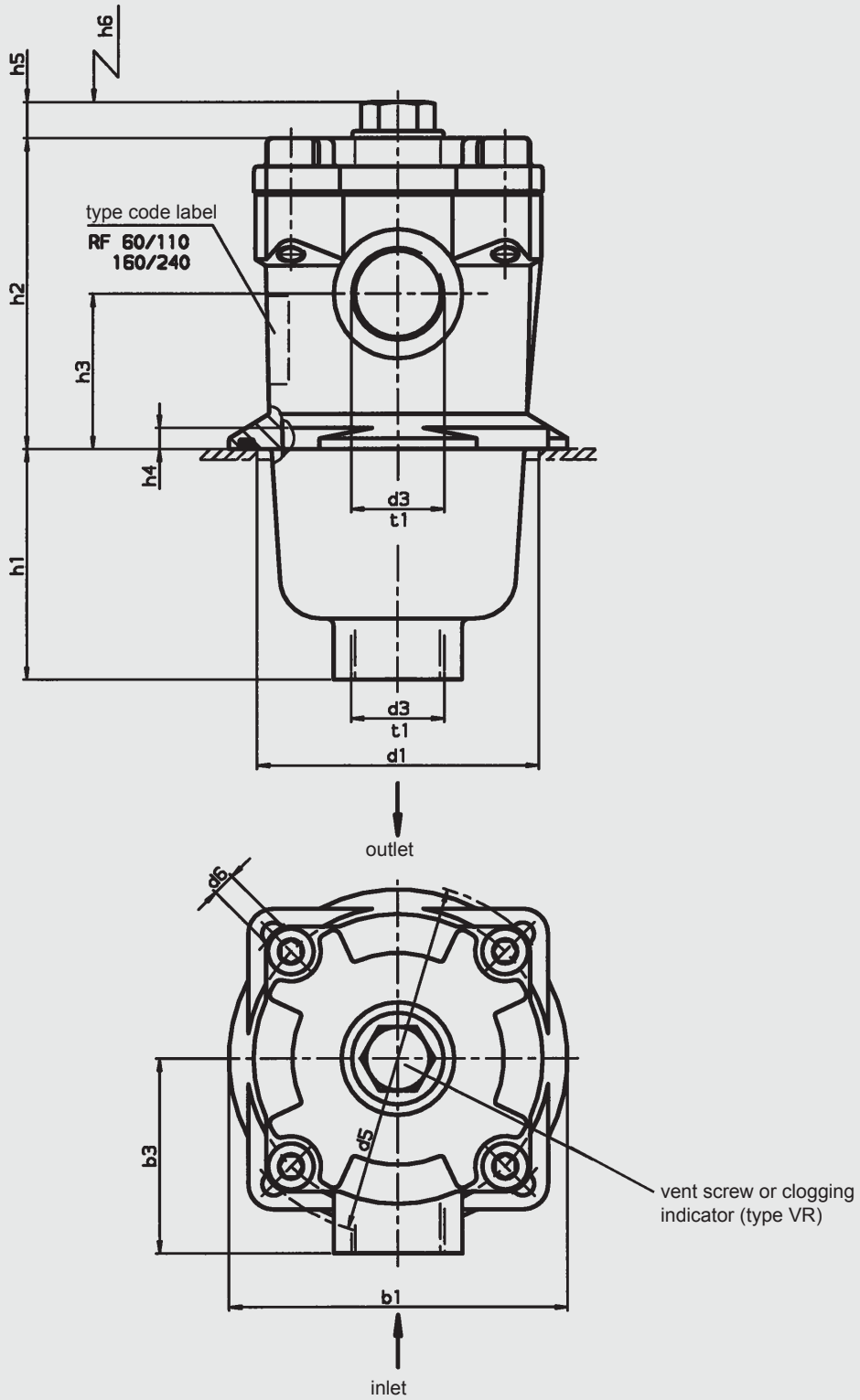

RF	b1	b3	d1	d3 ¹⁾	d5	d6 ²⁾	h1	h2	h3	h4	h5	h6	t1	t4	Weight including element [kg]	Volume of pressure chamber [l]
60	96	55	80	G 3/4	100	M5	66	88	44	6	12	80	17	-	0.9	0.40
110	96	55	80	G 3/4	100	M5	133	88	44	6	12	145	17	-	1.1	0.60
160	126	72	106	G 1 1/4	135	M6	89	108	54	6	12	120	20	-	1.8	1.00
240	126	72	106	G 1 1/4	135	M6	150	108	54	6	12	180	20	-	2.2	1.40

¹⁾ Threaded port to ISO 228 / ²⁾ Mounting hole for screw

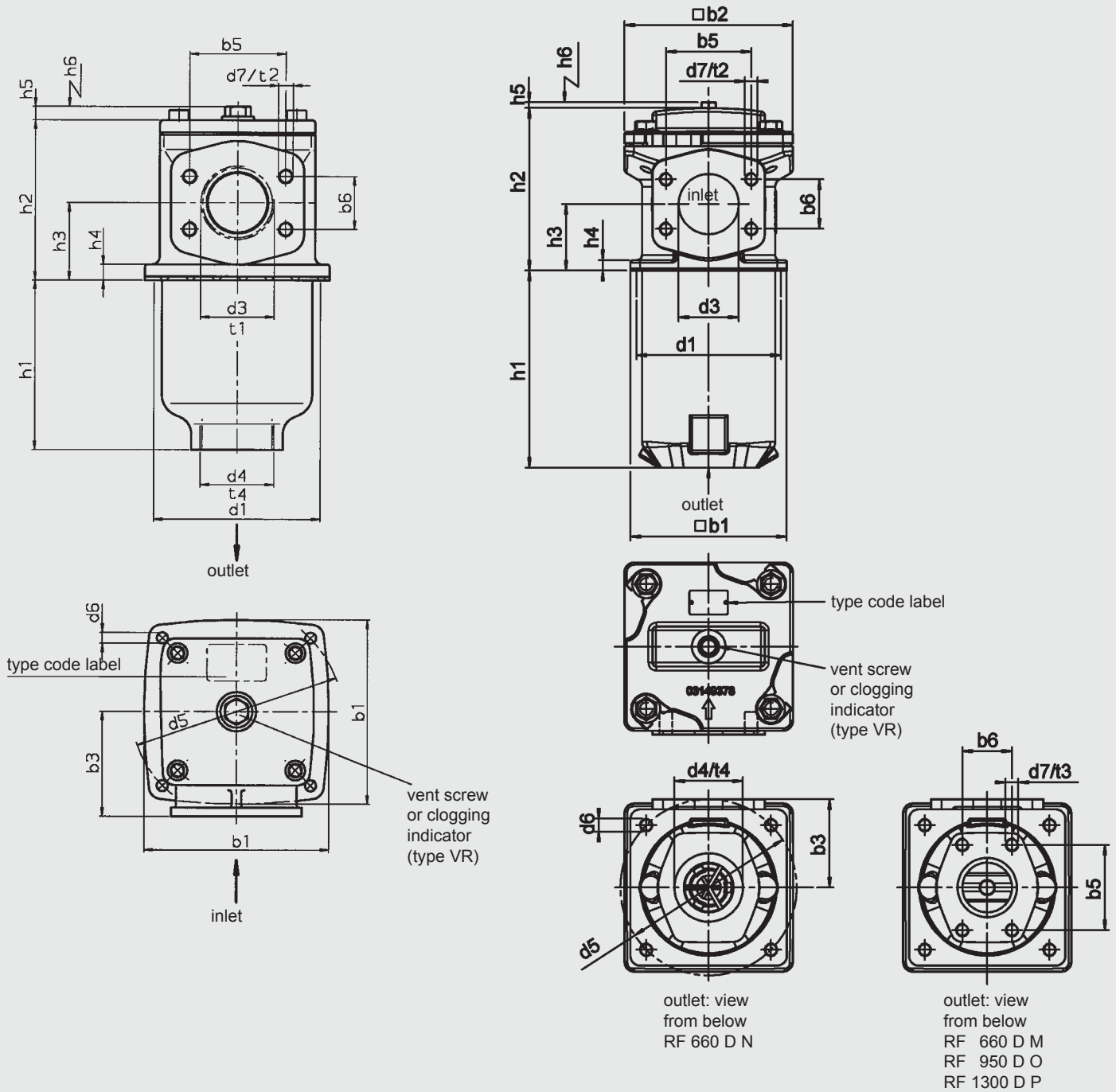

RF	b1	b2	b3	b5	b6	d1	d3	d4	d5	d6 ¹⁾	d7	h1	h2	h3	h4	h5	h6	t1	t2	t3	t4	Weight including element [kg]	Volume of pressure chamber [l]	
330	150	126	85	-	42.9	135	G2 SAE DN 50 (2")	G2	170	M8	M12	139	130	63	13	12	180	27	-	23	-	27	4.1	2.0
660	195	210	110	106.4	61.9	180	SAE DN 80 (3")	G3 SAE DN 80 (3")	220	M12	M16	246	203	83	13	8	320	-	28	18	28	31.0	6.8	
950	250	244	135	120.7	69.9	208	SAE DN 90 (3½")	SAE DN 90 (3½")	290	M16	M16	252.5	225	93	13	8	385	-	20	20	-	44.5	10.3	
1300	250	244	145	130.2	77.8	208	SAE DN 100 (4")	SAE DN 100 (4")	290	M16	M16	330.5	269	121	13	8	485	-	20	20	-	52.5	13.5	

Filter connection for SAE flanges to SAE-J 518c / 3000 PSI / ¹⁾ Mounting hole for screw

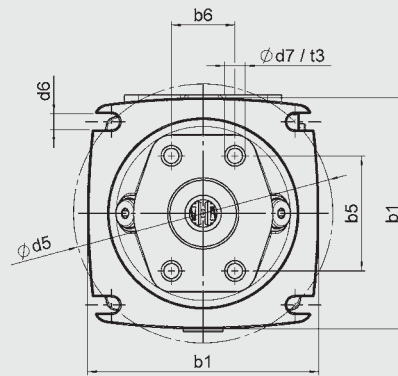
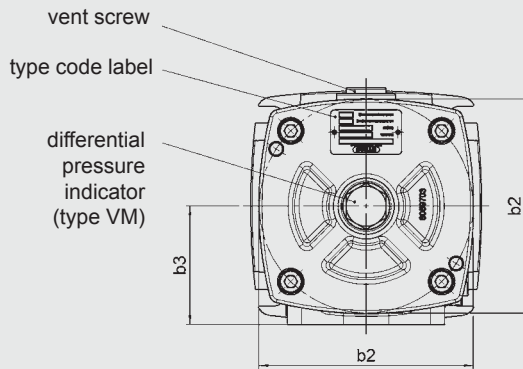
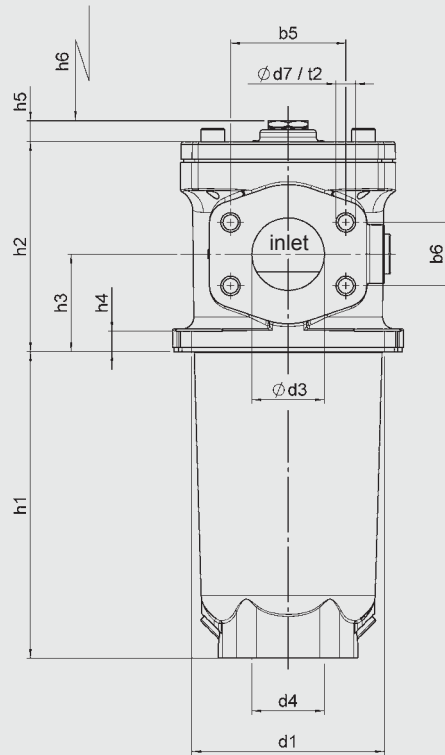

outlet: view from below
RF 450 C L
RF 580 C L

RF	b1	b2	b3	b5	b6	d1	d3	d4	d5	d6 ¹⁾	d7	h1	h2	h3	h4	h5	h6	t1	t2	t3	t4	Weight incl. element [kg]	Volume of pressure chamber [l]
450	156	144.5	80	77.8	42.9	130	SAE DN 50 (2")	SAE DN 50 (2")	175	M10	M12	207	142	66	14	14	345	-	22	22	-	6.6	2.7
580	156	144.5	80	77.8	42.9	130	SAE DN 50 (2")	SAE DN 50 (2")	175	M10	M12	507	142	66	14	14	645	-	22	22	-	9.4	4.7

Filter connection for SAE flanges to SAE-J 518c / 3000 PSI / ¹⁾ Mounting hole for screw

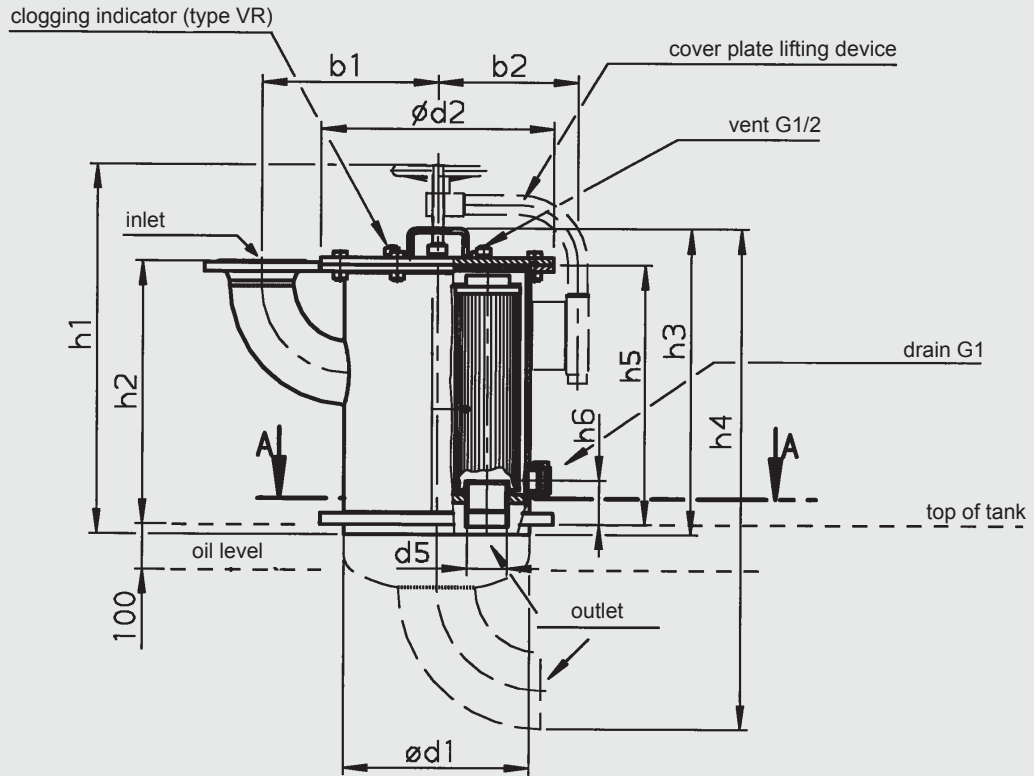

A-A

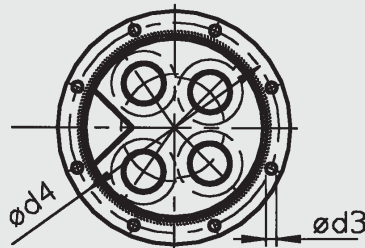

dimension h4 on request!

RF	Flange connection	h1	h2	h3	h5	h6	b1	b2	d1	d2	d3	d4	d5	No. of cover plate screws	Weight including element [kg]	Volume of pressure chamber [l]
2500	DIN DN 100	732	578	590	496	84	395	240	273	360	18	320	G2	8	55.3	26.0
	DIN DN 125		505				317								58.3	29.0
4000	DIN DN 125	738	501	596	496	84	355	282	356	450	18	410	G2	12	97.3	44.0
	DIN DN 150		540				388								101.3	48.0
5200	DIN DN 125	812	576	670	571	84	382	308	406	510	23	460	G3	8	119.1	64.0
	DIN DN 150		615				416								126.1	68.0
6500	DIN DN 150	817	615	680	571	84	470	358	508	620	26	572	G3	8	175.1	98.0
	DIN DN 200		720				535								186.1	108.0
7800	DIN DN 200	817	720	680	571	84	535	358	508	620	26	572	G3	8	187.1	108.0
	DIN DN 250		800				605								202.1	126.0
15000	DIN DN 250	817	800	709	571	84	712	460	711	840	26	780	G3	12	329.1	224.0
	DIN DN 300		866				777								382.1	247.0

NOTES

NOTE

The information in this brochure relates to the operating conditions and applications described.
For applications or operating conditions not described, please contact the relevant technical department.
Subject to technical modifications.

HYDAC FILTERTECHNIK GMBH
Industriegebiet
D-66280 Sulzbach/Saar
Tel.: 0 68 97 / 509-01
Fax: 0 68 97 / 509-300
Internet: www.hydac.com
E-Mail: filter@hydac.com

E 7.116.4/03.12