

BR CHT-KT(..)W - kołnierz tylni - gwint wewnętrzny

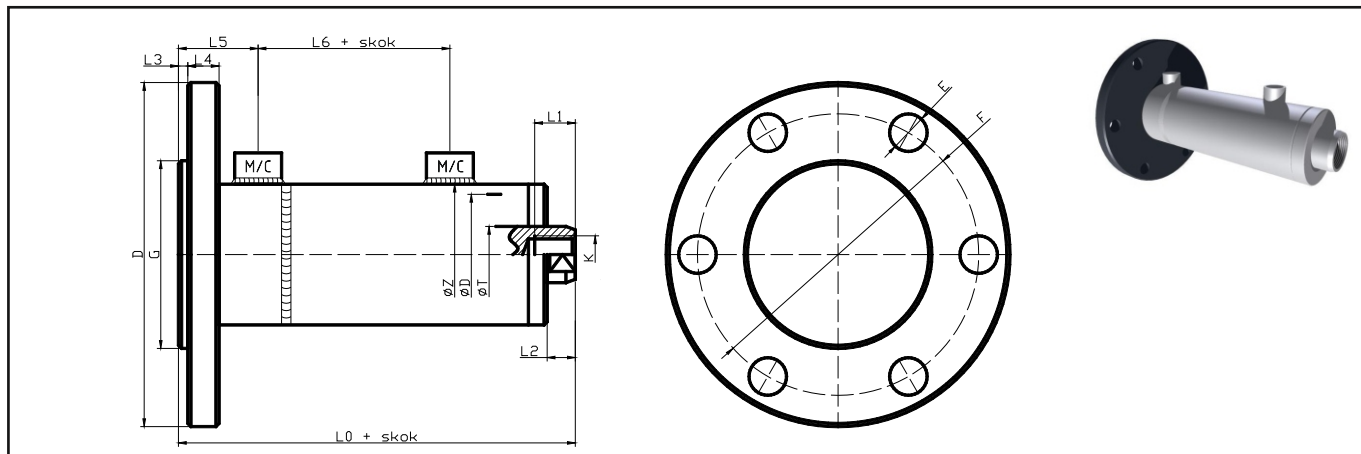

ØD	ØT	ØZ	D	F	E	G	L0	L1	L2	L3	L4	L5	L6	M [metr.]	C [cal.]	K
25	18	35	80	66	7	55	131	16	12	2	10	28	60	M14x1,5	G1/4"	M12x1,5
32	22	40	105	85	9	60	150,5	22	12	2	12	31	62,5	M14x1,5	G1/4"	M16x1,5
40	25	50	110	90	9	65	169	24	15	3	14	36	69	M16x1,5	G3/8"	M16x1,5
	28															
50	28	60	130	106	11	85	177	30	15	3	16	38	72	M16x1,5	G3/8"	M22x1,5
	32															
63	32	73	160	130	13,5	100	195	36	15	3	18	44	77,5	M22x1,5	G1/2"	M27x2
	36															
	40															
65	32	75	165	134	13,5	100	196	36	15	3	18	44	78,5	M22x1,5	G1/2"	M27x2
	36															
	40															
70	40	85	175	140	15	105	196	36	15	3	18	44	80	M22x1,5	G1/2"	M27x2
80	40	95	210	175	17	135	227	45	18	3	19	49	93	M27x2	G1/2"	M33x2
	45															
	50															
	55															
100	50	115	240	200	22	150	247	50	20	5	25	62	95	M33x2	G3/4"	M42x2
	55															
	60															
	70															
125	70	150	280	230	22	180	271	63	23	5	30	65	109	M33x2	G3/4"	M48x2
	80															
140	70	165	290	240	26	185	289	75	26	5	35	70	115	M33x2	G3/4"	M56x2
	80															
	90															
160	90	185	340	280	26	240	318	85	36	5	35	70	124	M33x2	G3/4"	M64x2
	100															
	110															
180	125	219	380	320	33	260	350	90	40	5	40	80	134	M33x2	G3/4"	M72x2

Siłowniki o wymiarach innych niż podane w tabeli, wg ustaleń z klientem.